

1. Product

Flexible Type 2 support for installation of signs located perpendicular to the wall.

2. Product Description

Flexible support for Type 2 signs

The support consists of a profile that allows Type 2 signs to be installed in locations where the sign may be subject to an impact, i.e. areas of fork-truck movement. It has been developed to allow 180 ° movement left and right (+90° and - 90°) without breaking or damaging the sign. The flexible area of rotation within the sign's profile has an elasticity coefficient which will return the sign to return to its original position following an impact.

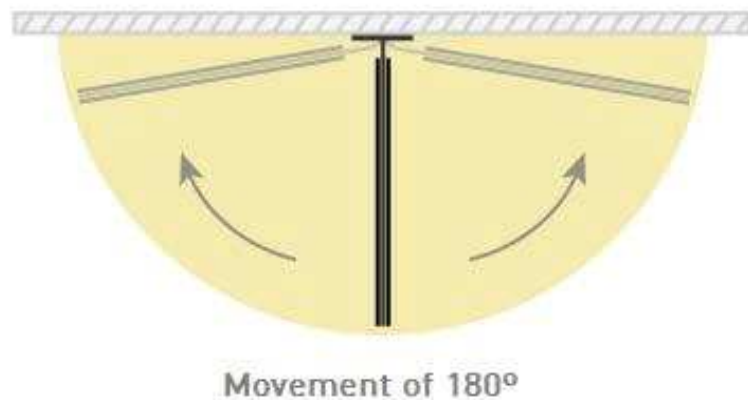
**3. Fixing and Application**

The support has been specifically developed to allow Type 2 signs (perpendicular) to be installed in areas of vehicle movement and cargo handling (i.e. warehouses, supermarkets, factories, etc.) where the likelihood of impacts, collisions and even potential acts of vandalism are high.

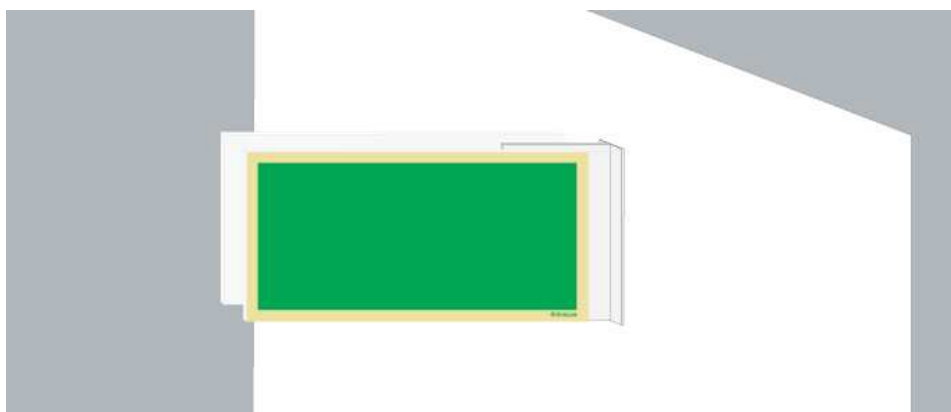

Alternatively, this profile can also be used when installing Type 2 signs on the ceiling.

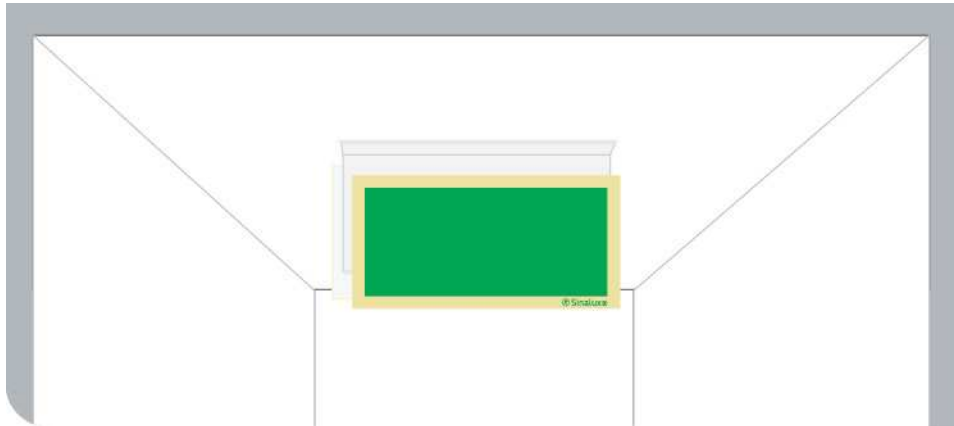

Installation of this sign type will always depend upon the surface the flexible support profile is to be attached to. Dependent on the receiving surface, the installer can use any of the following methods: screws & rawl-plugs, nails, double-sided adhesive tape, mastic or liquid adhesive. However, should the signs be installed using screws or nails, it is recommended that screw washers are also used to avoid damaging the integrity of the plastic through over-tightening. When installing Type 2 signs with a height greater than 300mm, it is also recommended that a minimum of three attachment points on each side of the profile are used.

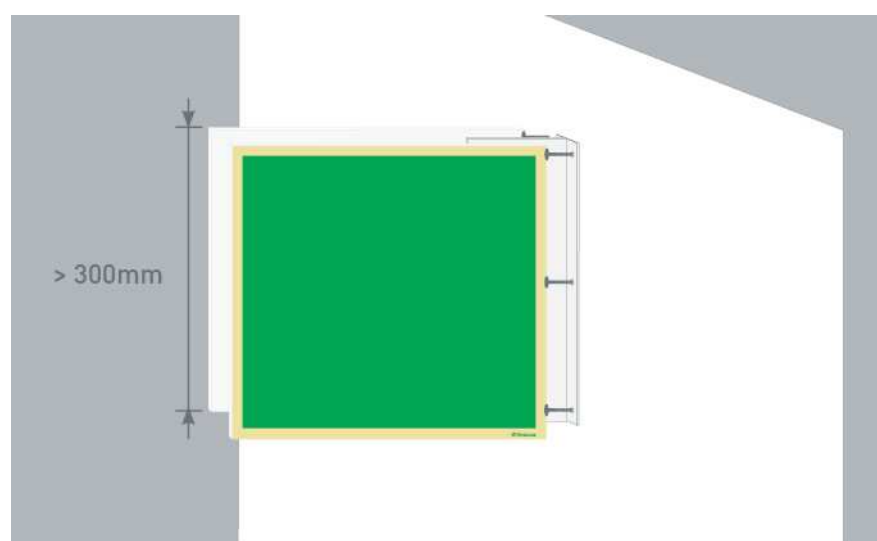

5. Technical Characteristics

| | |
|-----------------------------------|--------|
| Maximum Number of Movement Cycles | 1000 |
| Maximum Weight | 2.5 Kg |

6. Dimensions

The Type 2 flexible support is only suitable for the installation of signs with a maximum width of 400mm.

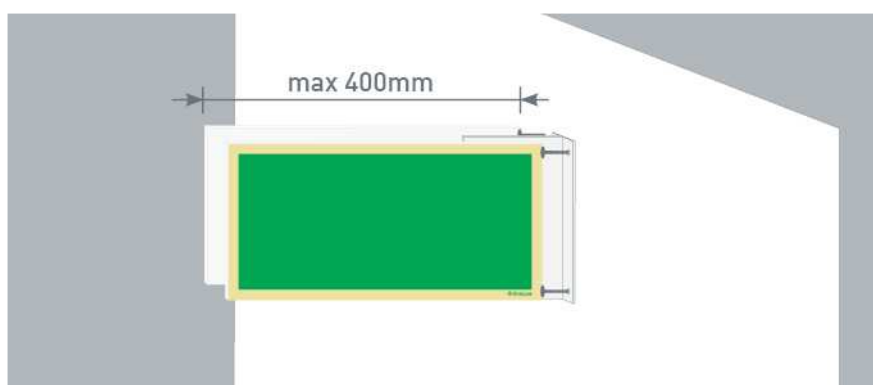
**6. Cleaning**

The product does not require any specific cleaning agent or cycle and can be kept clean using a dry, clean cloth or a cloth dampened with water and without detergent.

7. Warranty

In normal conditions with correct mounting and reasonable use Everlux offer a guarantee for 1000 movement cycles.

Note: One movement cycle is considered as a 180° movement (+90° and - 90°).